

450

Viral Kill Tower

Features and Benefits

- Utilizes a combination of self-contained ultraviolet light and room temperature oxidation to destroy viruses and Volatile Organic Compounds (VOCs)
- Technology recommended by the Center for Disease Control and Prevention, FDA, EPA and ASHRAE as effective against airborne coronavirus transmission
- Safe for use in occupied spaces 24 hours/day
- Destroys up to 99.9995% of airborne viral aerosols in indoor spaces
- Treats up to 9,000 cubic feet of air per unit
- Easy to clean – no contaminated filters
- Designed to blend into the decor of your space (available in ten finishes and four countertop options)
- Bulb life up to 8,800 hours
- IoT compatible with OpenKitchen (ConnectWare required)
- One-year limited warranty

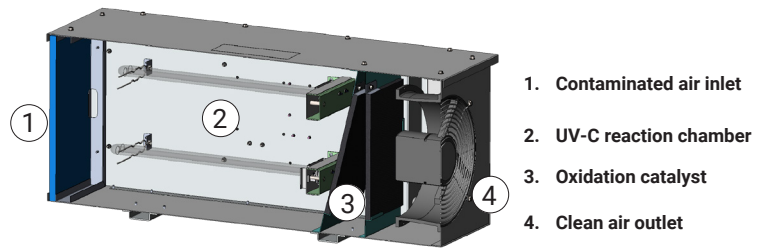

Reduction of MS2
Bluezone 450

Bioaerosol Type	Species	Trial ID		15 min.	30 min.	45 min.	60 min.
Virus	MS2 bacteriophage (RNA E. coli phage)	T1	Net Log Reduction	-1.52	-3.25	-4.25	-5.52
			Net % Reduction	96.9552%	99.9439%	99.9944%	99.9997%
		T2	Net Log Reduction	-1.48	-3.59	-5.05	-5.20
			Net % Reduction	96.7060%	99.9740%	99.9991%	99.9994%
		T3	Net Log Reduction	-1.75	-3.34	-4.50	-5.24
			Net % Reduction	98.2128%	99.9540%	99.9968%	99.9994%
Average Net Log Reduction				-1.58	-3.39	-4.6	-5.32
Average Net % Reduction				97.291%	99.957%	99.9968%	99.9995%

This study was conducted in compliance with FDA Good Laboratory Practices (GLP) as defined in 21 CFR, Part 58 using aerosolized MS-2 bacteriophage, a surrogate for SARS-COV-2, in a room-sized test chamber.

450

Viral Kill Tower

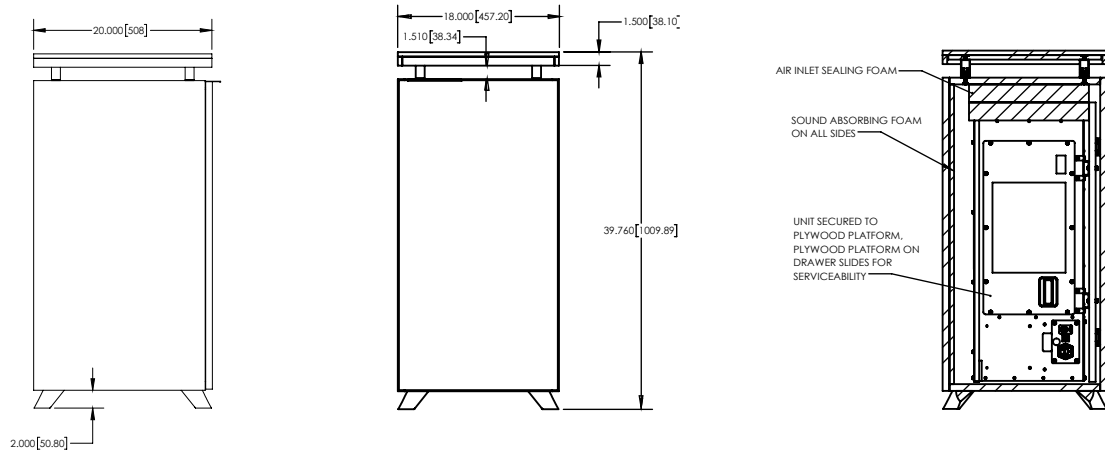

TOWER ONLY SPECIFICATIONS

Dimensions	20" X 18" X 39.76" (508 mm X 457 mm x 1010 mm)
Weight	96 lb. (44 kg.)
Shipping Dimensions/Weight LTL Freight Class 250	30" x 30" x 46" (762 mm x 762 mm x 1184 mm) / 146 lb. (66 kg.)

BLUEZONE UNIT ONLY SPECIFICATIONS

Dimensions	31" X 15" X 13.5" (79cm X 38cm x 34cm)
Weight	26 lb. (11 kg.)
Shipping Dimensions/Weight	36" x 20" x 20" (914 mm x 508 mm x 508 mm) / 28 lb. (13 kg.)
Input Voltage and Current	120 VAC, 1-phase, 3 amps 240 VAC, 1-phase, 1.5 amps
Electrical Connection	IEC 320-C13
Storage Environment	-4° F – 150°F / -20° C – 65° C
Treatment Volume	Up to 9,000 cubic feet
Power	310 Watts max at 120 VAC. 350 Watts max at 240 VAC
Certifications	cETLus Listed CE Mark UL 2998 zero ozone emissions